

# User Manual

MODEL: QM 350i



# Contents

---

<b>Safety Precautions</b> .....	<b>1</b>
<b>General Description</b> .....	<b>3</b>
<b>Getting The Best From Your QM350i</b> .....	<b>4</b>
<b>Flying the QM350i</b> .....	<b>6</b>
<b>QM350i Specifications</b> .....	<b>8</b>
<b>QM350i Reference Diagram</b> .....	<b>9</b>

## Safety Precautions

- Be sure to read the instructions in this section carefully before use.
- Make sure you observe the instructions in this manual as the conventions of safety symbols and messages are very important.
- We also recommend you keep this instruction manual handy for future reference.

## Safety Symbol and Message Conventions

Safety symbols described below are used in this manual to prevent bodily injury and property damage which could result from mishandling. Before operating your product, read this manual first and understand the safety symbols and messages so you are thoroughly aware of any risks.



### **WARNING**

Indicates a potentially hazardous situation which, if mishandled, could result in death or serious personal injury.





## WARNING

### When Installing the Unit

- Do not expose the unit to rain or an environment where it may be exposed to water or other liquids, as doing so may result in damage to the bass driver or corrosion of the steel protective grill.
- Do not cut, kink, otherwise damage nor modify the speaker cable. Also use speaker cable of at least 1.5mm core diameter. In addition, avoid locating the speaker cables close to heaters, high traffic areas or locations where the cables can be damaged.
- Avoid installing or mounting speaker boxes in unstable locations and when flying, use the hardware designed for the speaker box and fix securely to a solid wall. Failing to do so may result in the unit falling, causing personal injury and/or property damage.
- Be sure to ground to the safety ground (earth) terminal to avoid electric shock. Never ground to a gas pipe as a catastrophic disaster may result.
- Never hang a speaker box from only one rigging point. Use multiple points and attach a safety line to a point strong enough to take the weight of the speaker box.

### When the Unit is in Use

- Turn down the amplifier before switching on the amplifier. If there is no sound, check the speaker connections. Speaker connectors must be locked in place.
- Should any of the following irregularities be found during use, immediately switch off the amplifier power, disconnect the power supply plug from the AC outlet and contact your nearest Quest dealer:
- If you detect smoke or a strange smell coming from the unit,
- If the unit falls and the unit case is damaged,
- If it is malfunctioning (no HF or low frequency output).

Make no further attempt to operate the unit if it is found to be in any of the above conditions as this may cause fire or electric shock.

2

## General Description

The QM350i is a passive two way bass reflex design speaker suitable for mobile or installation use. The design characteristics of the QM350i make it suitable for both full range use or as the high-mid component of a multi way system with sub-bass enhancement.

The new generation neodymium high frequency transducer is matched to a rotatable asymmetrical wave guide that can be rotated through 270 degrees for horizontal, vertical or fold-back monitor installation.

The asymmetrical coverage allows the horn to achieve both long throw performance and wide angle close coverage without “hot zones” or adding to unnecessary room reflections that can degrade vocal intelligibility. The unit can be used in a stand alone configuration or as part of a system coupled with any Quest sub-bass system. When used in conjunction with these devices, the QM350i will form part of a high performance multi way audio system.

## Installation

Temporary installation is possible with the 35mm floor stand mounting in the base of the enclosure. Fold-back installation can give extra uniform stage performance by rotating the horn flare to the “fold-back” position.

Five M 8 thread inserts are located on the top, sides and one under the QM350i enclosure.

These are intended to be used with the WB350i wall bracket.

### QM Range Flying Accessories

Two rigging accessories are available for the QM350i:

WB 350i Wall bracket kit

QB450 Protective transit cover

### Functional Design

The QM350i features an asymmetrical horizontal angle along one side which makes it suitable for use as a stage\foldback wedge when laid flat. The QM350i can be easily maneuvered across a stage or down a loading ramp by one person.

### Solid Build Construction

The QM350i is well suited to all professional applications. The synthetic casing is specially formulated to withstand demanding use and the heavy gauge power-coated steel grill ensures the driver and horn are always protected.



## WARNING

Flying the box from one insert must not be attempted! Improper installation may result in damage, injury or death.

## Getting The Best From Your QS350i

### Connections

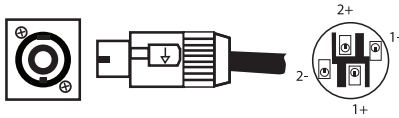

Two Neutrik™ Speakon model NL-4 connectors are mounted in a removable panel on the rear surface of the box.

The connector input is wired pin 1+ and pin 1-.

Pin 2 is not connected.

Take care when inserting the Speakon connector twisting the connector until it locks into place. Reverse the procedure to disconnect.

### Suitable Amplification

The QM350i is an 8 ohm enclosure and can be connected in multiple parallel connections to an amplifier channel that can operate at speaker impedances of 4 ohms.

The QM350i is a mid power level high efficiency system, so ultra high power is not necessary to obtain high sound pressure levels. The recommended power range per amplifier channel is 350 - 500 watts RMS into an 8Ω load or up to 1,000W RMS into a 4 ohm load. An ideal partner to the QM350i are any of the Quest QA range of amplifiers. Setting the QA amplifier's high pass filter at 35Hz is recommended for full range applications. If you are intending to add sub bass speakers, the high pass filter can be set to 80Hz.

4

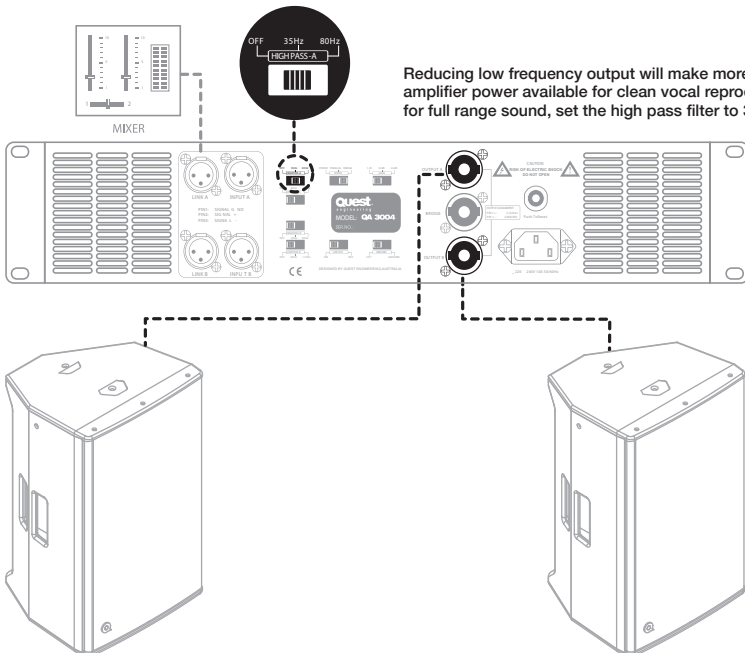

Reducing low frequency output will make more amplifier power available for clean vocal reproduction for full range sound, set the high pass filter to 35Hz

**Recommended QM350i Amplifier Configuration**

**Speaker cables**

Speaker cable needs to be as heavy gauge as conveniently possible for low-loss results. Light gauge cable (below 1.5mm) will create extra resistance and waste amplifier power. This particularly applies to long speaker runs. The amplifier’s damping factor statistic (“punch” for the non technical) is greatly diminished, so keep your speaker cables short and as heavy gauge as practical.

**Speaker Placement as a Single Box or in Arrays**

The QM350i is intended for use as a single speaker system or as part of a multiple speaker setup with or without sub bass reinforcement. It can also be installed in small arrays of up to three boxes per array for very wide coverage applications. When a group of point source 90 degree speaker boxes are placed together, it is possible to have “interference effect” between some of the boxes causing uneven frequency response.

This can be particularly noticeable in the mid-high frequency area. If you intend to set up the QM350i as part of a multiple box array, see the section ‘Flying the QM350i’.

When positioning the speaker system on a stage, make sure the HF horn at the top of the speaker box is above the heads of the audience. At full power the output of the QM350i is very high and hearing damage can result from short to medium term exposure. When used as a drum-fill monitor on a stage, the box can sit on the stage however consider that the HF horn will be at ear level for the average drummer setup.

For best results when the QM350i is used as a front of house speaker, consider angling the box forward slightly to direct the HF horn to cover the audience area. The HF horn should be aimed away from the ceiling and focused on the intended area of coverage. This will minimize HF reflections, lower the reverberant field in the room and give better intelligibility.

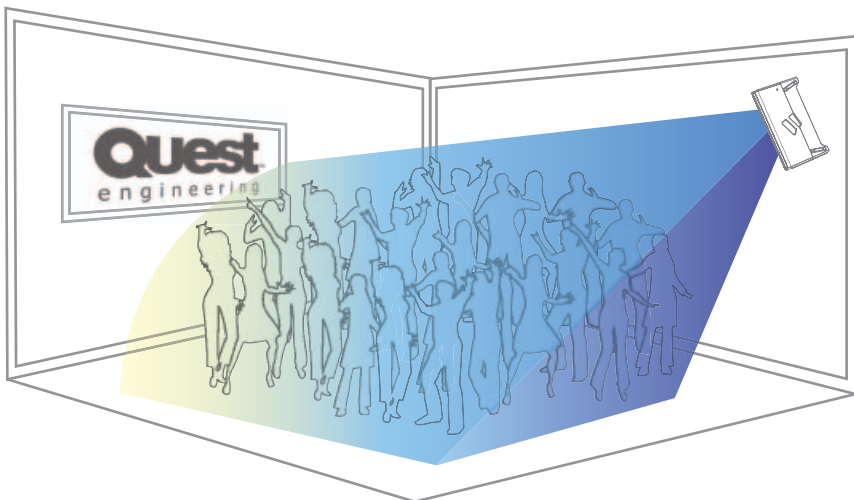

**Ideal QM350i Flown Configuration**

## Flying the QM350i

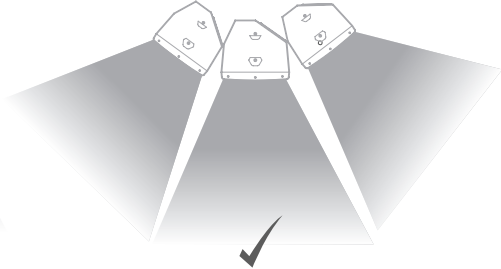

Before suspending any speaker system always inspect all components (enclosure, rigging frames, track fittings, etc.) for cracks, deformations, corrosion, missing, loose or damaged parts that could reduce strength and safety of the array. Do not suspend the speaker system until the correct preparation of the installation site has been taken to avoid health risks during and after the completion of the installation. A licensed Professional Engineer must approve the placement and method of attachment to the structure prior to the installation of any overhead object.

### Rotating the Horn Flare

The asymmetrical horn flare can be rotated through three separate planes of dispersion depending on the speaker box requirement and installation environment. The planes are vertical installation, horizontal installation and foldback monitor.

Good coverage of audiences often requires wide dispersion at the base of the horn flare to cover close listeners and a focused narrow dispersion at the top of the flare to beam to the back of the room.

The QM350i horizontal horn covers both “short-throw” and “long-throw” requirements in a single system.

For the majority of installations (where the box is installed vertically), the asymmetrical horn should be used as supplied and will not need to be rotated.

For horizontal installation rotate 45 degrees so the arrow is pointing at the floor side so as to have the “beaming” facility at the top of the horn.

### Foldback HF coverage

For stage foldback monitors the coverage must be wide when performers are close to the wedge and beam down the stage to minimize the spill off the stage that may interfere with the main PA.

For floor monitor use the horn must be rotated with its “wide” dispersion (arrow indicator), side directed towards the top of the horizontal floor cabinet.

When removing and reinstalling the front grill to rotate the horn, ensure the nuts are not over tightened as this may make them difficult to remove in future or cause them to break.

If damaged, the cage nuts can be replaced easily with standard rack mount cage nuts.

6



## WARNING

Ensure the box is securely located. If any doubt about the physical stability, tie the box down with ratchet straps to a secure base.



**QM350i Wave Guide Examples**

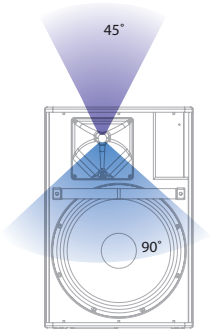

**QM350i FOH Configuration (front)**

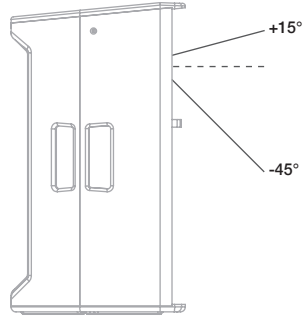

**QM350i FOH Configuration (side)**

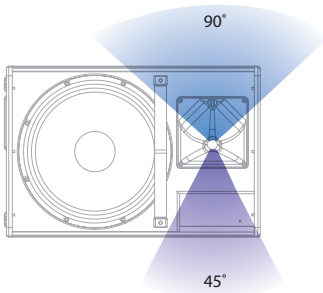

**QM350i Foldback Configuration (front)**

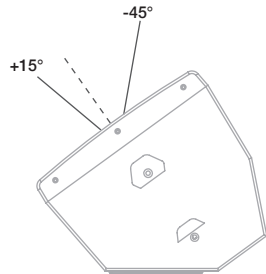

**QM350i Foldback Configuration (side)**

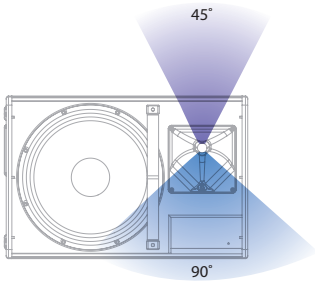

**QM350i Horizontal Configuration (front)**

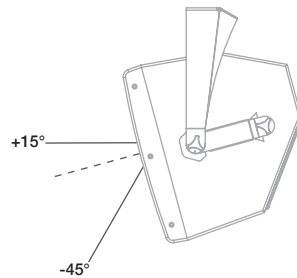

**QM350i Horizontal Configuration (front)**

## QM350i Specifications

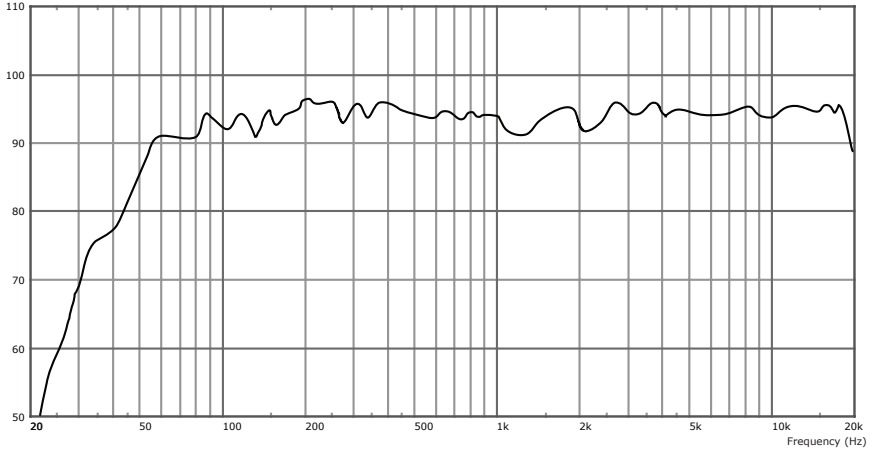

8

— QM350i - Frequency Response - 2.83V/1m

Technical Parameters	
Power Handling	400W RMS
Frequency Response	60-19kHz (+/-3dB)
Sensitivity	95dB @ 1kHz
Maximum SPL @ 1m	128dB
Impedance	8 ohms
Connections and Wiring	2 x Speakon NL4 - 1+/-1- (2+/-2- through)
Woofer	12" High Power Mid-Bass Woofer
Tweeter	1" Neodymium Compression Driver
Directivity	Asymmetric +15/-45 Vertical   45/60 Horizontal
Dimensions	620x380x346.5 mm
Weight	19.7 kg Net

## QM350i Reference Diagram

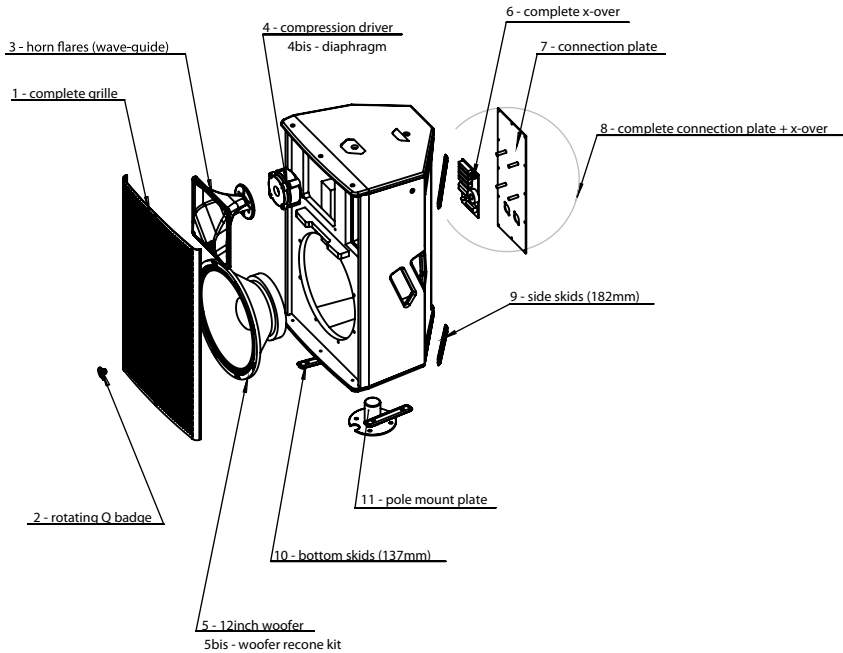

9

No.	Description	Spare Part
1	Complete Grill (with Acoustic Foam)	HGQM350
2	Rotating Q-badge (23mm) with Spring Loaded Pin	HQB25
3	Horn Flare (Wave Guide)	HWG350
4	1" Compression Driver	T1009
4bis	1" Compression Driver Diaphragm	RT1009
5	12" Woofer	T12001
5bis	12" Woofer Recone Kit	RT12001
6	Complete X-Over	HXQM350
7	Connection Plate	HCPQM350
8	Complete Connection Plate and Complete X-Over	HCCPQM350
9	Long Skids (182mm)	HSK182
10	Medium Skids (137mm)	HSK137
11	Pole Mount Plate	HPP350

## Register Your Product

Thank you for choosing Quest. Please take the time to complete your product registration card which is included with the packaging.

Registering your Quest Engineering product will:

- CONFIRM YOUR WARRANTY
- REGISTER YOUR PRODUCT
- PROTECT YOUR NEW PRODUCT

**REGISTER ONLINE:**

[www.questaudio.net/registration](http://www.questaudio.net/registration)

**quest**<sup>™</sup>  
engineering

[www.questaudio.net](http://www.questaudio.net)